

Reentrant Activity in a Virtual 3D Ventricular Slab Preparation Subject to Regional Simulated Ischemia: Role of the Ischemic Zone Size

L Romero¹, E Heidenreich², JF Rodriguez², B Trenor¹,
JM Ferrero¹, J Saiz¹, M Doblare²

¹Universidad Politecnica de Valencia, Valencia, Spain

²Universidad de Zaragoza, Zaragoza, Spain

Abstract

Many aspects about generation of reentrant arrhythmias during regionally acute ischemia remain unclear. The goal of the present work is to study the effects of the size of the central ischemic zone (CZ) in a realistic 3D tissue by means of computer simulations.

Simulations were run using a modified version of the Luo-Rudy dynamic action potential model (LRd00) and accounting for fiber orientation in the slab preparation.

Our results show that, for a non centered ischemic zone of 25 mm in diameter, premature stimuli applied at coupling intervals comprised between 167 ms and 190 ms lead to reentry. Therefore, the width of the vulnerable window (VW) for re-entry yields 24 ms while for 20 mm in diameter, the VW shrank to 19 ms. In addition, for bigger CZ diameter, figure-of-eight reentries are initiated closer to the epicardium. In conclusion, in a 3D regionally ventricular slab, a bigger size of the ischemic zone widens the VW for reentry.

1. Introduction

Ventricular tachycardia (VT) and ventricular fibrillation (VF) are potentially lethal arrhythmias frequently caused by reentrant electrical activity in heart ventricles [1]. During acute myocardial ischemia, important electrophysiological cellular changes take place, favouring the occurrence of these episodes [1]. Indeed, its three main components, it is, acidosis, hyperkalemia and hypoxia affect action potential (AP) morphology and propagation. These changes only affect those areas fed by the occluded coronary artery, creating a high heterogeneity that becomes the substrate for reentrant arrhythmias generation.

In anatomical reentries, the excitatory wave travels around an anatomical unexcitable obstacle. However, during ischemia phase Ia, barriers are functional instead of anatomical, so pathways are formed around the areas

temporally unexcitable [2]. In fact, acute ischemia tends to prolong refractoriness, setting the stage for unidirectional block (UDB), which leads to reentry. So, we hypothesize that expansion of the CZ may enhance reentrant activity generation. For this purpose, we have studied the effect of the CZ on the vulnerability to reentry in a virtual 3D ventricular slab preparation subject to regional acute ischemia and accounting for a realistic fiber orientation.

2. Methods

Cellular electrical activity was simulated using a modified version of the Luo-Rudy dynamic AP model (LRd00) [3].

AP propagation obeys the equation governing continuum mono-domain models:

$$\nabla \cdot (\bar{\sigma}_i \cdot \nabla V) = \chi \cdot C_m \cdot \frac{\partial V}{\partial t} + \chi \cdot q_{ion} + \chi \cdot q_{stim}$$

with V being the transmembrane potential, $\bar{\sigma}_i$ the anisotropic conductivity tensor, C_m the membrane capacitance, χ the volume to surface ration of the cell, q_{ion} the ionic current and q_{stim} the stimulus current.

Acute ischemia was simulated taking into account its three main components by setting the values of the parameters affected by ischemia to those experimentally observed at minute ten of ischemia. Firstly, hypoxia was considered by partially activating the ATP-sensitive K^+ current ($I_{K(ATP)}$), formulated by Ferrero Jr. et al. [4]. For this purpose, intracellular concentration of ATP and ADP were increased from 6.8 mmol/L and 15 μ mol/L in the normal zone (NZ) up to 5 mmol/L and 99 μ mol/L in the central zone (CZ) respectively [5, 4]. Secondly, hyperkalemia was simulated by elevating extracellular K^+ concentration ($[K^+]_o$) from its normal value (5.4 mmol/L) in the NZ up to 12.5 mmol/L in the CZ [5, 6]. Finally, acidosis was mimicked by its effect on the Na^+ and Ca^{2+}

current [7, 8]. Thus, the fast inward Na^+ current (I_{Na}) and the Ca^{2+} current through the L-type channels ($I_{\text{Ca(L)}}$) were affected by a factor f_{pH} of 0.875 in the CZ [7, 8].

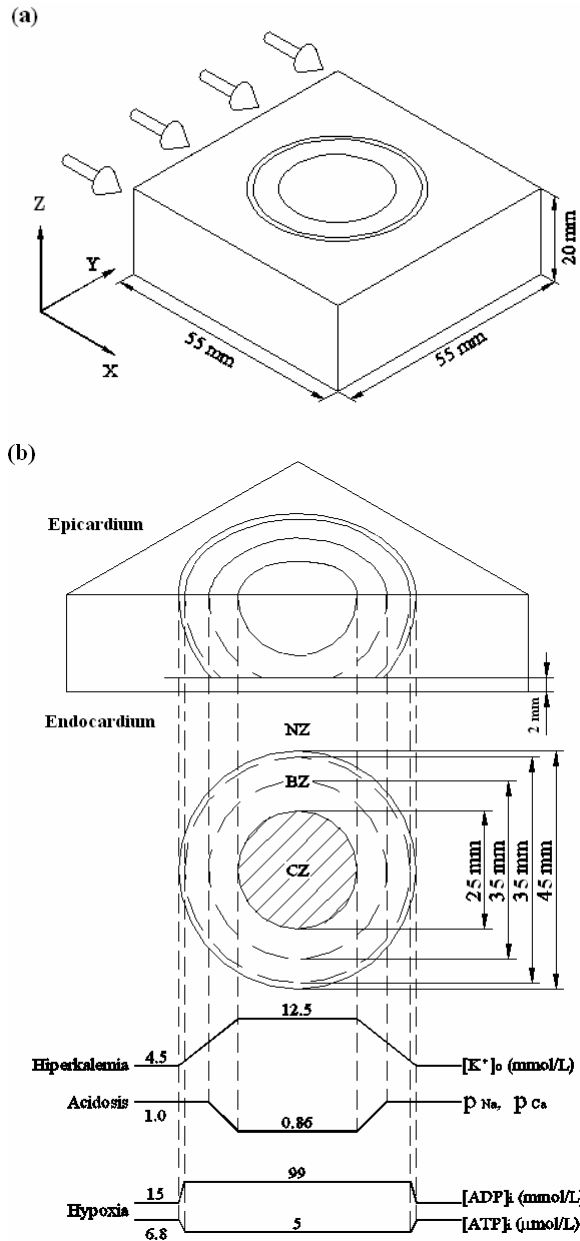

Figure 1. 3D representation of the virtual ischemic tissue. (a) Illustration of the 3D slab preparation and (b) description of the different regions of the tissue: normal zone (NZ), border zone (BZ) and central ischemic zone (CZ).

Figure 1 (a) depicts the 5.5 cm x 5.5 cm x 2 cm cardiac slab, which includes a NZ and a non centered spherical CZ of 2 cm in diameter surrounded by a 1 cm thick ring-

shaped ischemic border zone (BZ). In the ischemic BZ, all parameters return to their normal values along linear spatial gradients (see Figure 1, panel (b)), according experimental observations reported by Coronel [9]. Specifically, hyperkalemia experienced a linear increase along 1 cm of tissue, intracellular concentration of ATP and ADP varied along 0.1 cm of tissue and sodium and calcium channels activation decreased along the inner 0.5 cm of the BZ. A 2 mm thick NZ was also considered in the endocardium to simulate the wash up carried by the interventricular blood.

Details about the numerical aspects regarding 3D slab are explained in previous publications from our group [10].

Orientation of the cardiac muscles and their imbrication were simulated by linearly varying the both angles from -60° and 0° in the epicardium to $+60^\circ$ and 10° in the endocardium respectively (further information in [10]).

The stimulation protocol consisted of two planar current pulses (S1–S2), of 5 ms in duration and an amplitude of 1.5 times the diastolic threshold. Both pulses were delivered at the base of the slab defined by the yz plane (Figure 1 (a)). S1 was delivered 75 ms after the simulation initiation to allow variables to reach the steady state and S1-S2 coupling interval (CI) was variable.

In this paper, probability to reentry was measured by means of the vulnerable window (VW), defined as the interval of CIs for S2 delivery that led to reentrant activity

3. Results and discussion

Conducted simulations in the 3D slab preparation with 25 mm in diameter of the CZ resulted in figure-of-eight reentry whenever premature stimuli was applied at CIs comprised between 167 ms and 190 ms. So, the width of the VW for reentry yielded 24 ms. This VW was 5 ms longer than the one obtained for an identical preparation but for a 20 mm in diameter of the CZ. Therefore, expansion of the ischemic zone size in a 3D virtual slab preparation resulted in a widening of the VW. Indeed, the VW in the slab with 20 mm in diameter of the CZ corresponded to the interval comprised between 167 and 185 ms. Therefore, widening of the VW resulted from the displacement of its upper limit to longer CIs. In fact, the broader ischemic zone provoked the unidirectional block (UDB) appearance even at longer CI, when the tissue was more recovered from inexcitability. This phenomenon may lie on the decrease of the safety factor of conduction in less concave wavefronts. In our previous work, we demonstrated that wavefront curvature plays a major role in the safeness of propagation [11]. In fact, the longer the diameter of the ischemic zone, the less concave the

wavefront becomes. So, in this case, a reduction of the SF might enhance the probability to reentry, which is in accordance with our previous work [12].

Figure 2 displays colour-coded snapshots of the membrane potentials for the reentry provoked by an extra stimulus of 187 ms of CI. This figure shows the activation sequence developed in the mid-plane (Figure 2 (a)) and in the plane where the reentry initiates (Figure 2 (b)). During the interval comprised between 525 ms and 725 ms, the impulse propagated retrogradly through the CZ near the epicardial surface (Figure 2 (b)) while there is no electrical activity in the mid plane (Figure 2 (a)). Therefore, reentrant episodes were originated close to the epicardium and then propagated through the neighbouring layers exciting the whole slab. This pattern of propagation may lie on the location of the ischemic zone, which was displaced 3.5 mm from the mid plane to the epicardium.

In addition, propagation was affected by fiber orientation. As shown in Figure 2 (Panels (a) and (b)), the stimulus started propagating in a planar way. As time

progressed, differences between layers were noticed by comparing propagation in both planes, mid plane ((Figure 2 (a)) and near the epicardium (Figure 2 (b)). Indeed, patterns of excitation were influenced by fiber orientation not only of that very plane but also of the contiguous layers. This effect became more evident when the AP penetrated the CZ ($t \in [525 \text{ ms}, 725 \text{ ms}]$) as electrical activity was nearly exclusive near the epicardium. Since then on, activation was generated in that area and therefore highly influenced by its characteristics (Figure 2 (b)). In fact, excitation took place almost symmetrically in the mid plane during the first 775 ms, when reactivation of the proximal BZ and NZ started with a rotation angle of -30° approximately instead of horizontally. In fact, reentry occurred where fiber orientation is -45° approximately, as shown in Figure 2 (b) instant 725 ms. Immediately, excitation spread through the ventricular wall (z axis). As fibers rotate along this direction, becoming more horizontal, the shape of the depolarizing wave was modified.

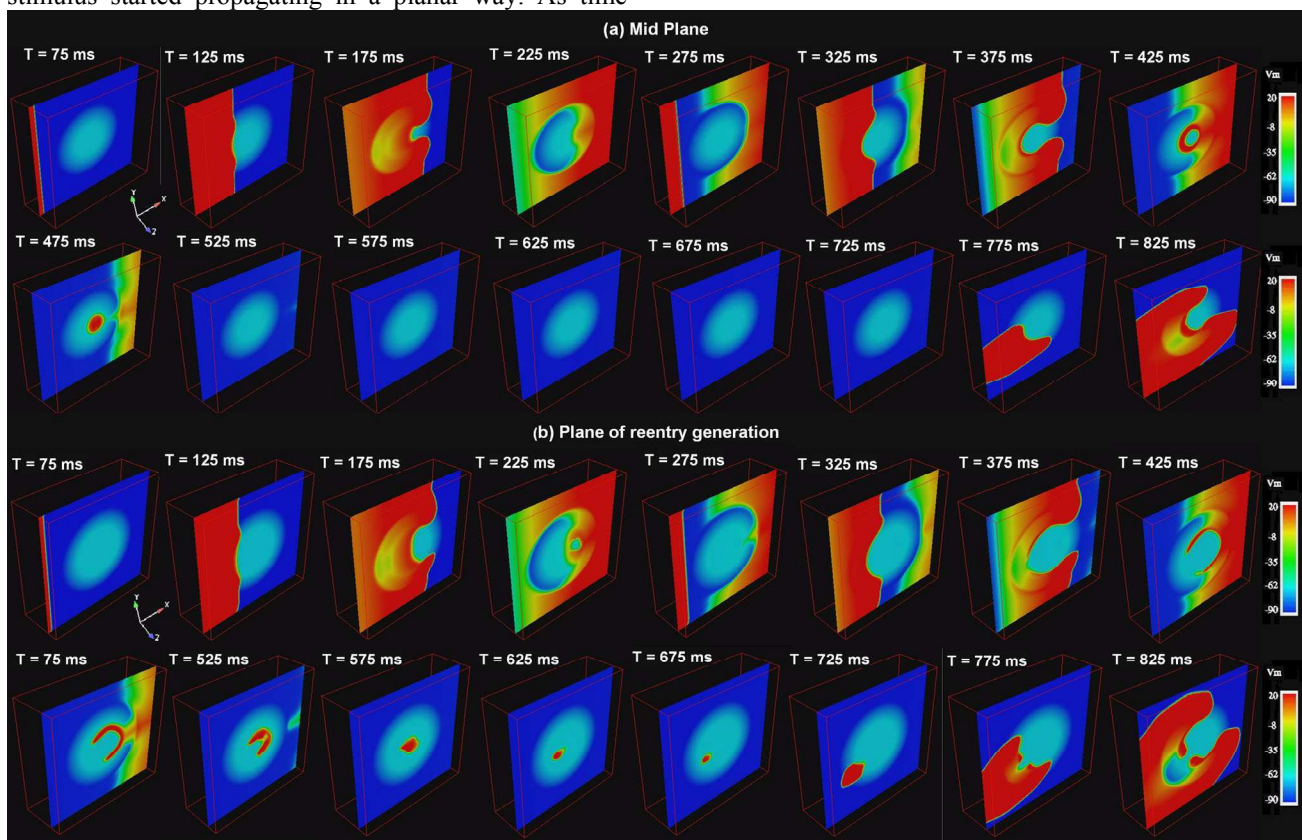

Figure 2. Activation sequence during acute regional ischemia in a virtual 3D ventricular slab preparation. Color-coded voltage snapshots of the virtual tissue after S1-S2 stimulation for a CI of 187 ms. Red color indicates depolarized voltage and blue color repolarized voltage. Snapshots are separated by 50 ms intervals, starting at S1 delivery. Section (a) illustrates the pattern of activation in the mid plane of the slab whereas section (b) represents the plane where reentry is generated

4. Conclusions

Our study reveals that vulnerability to re-entry is strongly dependent on the size of the ischemic zone. In a 3D regionally ventricular slab, expansion of the ischemic zone widens the VW for reentry and the exact location of its initiation depends on the location of the ischemic zone.

Acknowledgements

This work has been partially supported by the Plan Nacional de Investigación Científica, Desarrollo e Innovación Tecnológica del Ministerio de Educación y Ciencia of Spain (TEC2005-04199).

References

- [1] Wit AL, Janse MJ. Futura Publishing Co. ed. Mount Kisko. The ventricular arrhythmias of ischemia and infarction: electrophysiological mechanisms. 1993.
- [2] Allesie, M. A., F. I. Bonke, and F. J. Schopman. Circus movement in rabbit atrial muscle as a mechanism of tachycardia. III. The "leading circle" concept: a new model of circus movement in cardiac tissue without the involvement of an anatomical obstacle. *Circ. Res.* 1977; 41:9-18.
- [3] Faber GM, Rudy Y. Action potential and contractility changes in $[Na^{+}]_i$ overloaded cardiac myocytes: a simulation study. *Biophys J.* 2000; 78(5):2392-2404.
- [4] Ferrero JM, Jr., Saiz J, Ferrero JM, Thakor NV. Simulation of action potentials from metabolically impaired cardiac myocytes. Role of ATP-sensitive K^{+} current. *Circ. Res.* 1996; 79(2):208-221.
- [5] Weiss JN, Venkatesh N, Lamp ST. ATP-sensitive K^{+} channels and cellular K^{+} loss in hypoxic and ischaemic mammalian ventricle. *J Physiol* 1992; 447:649-673.
- [6] Coronel R. Heterogeneity in extracellular potassium concentration during early myocardial ischaemia and reperfusion: implications for arrhythmogenesis. *Cardiovasc. Res.* 1994; 28(6):770-777.
- [7] Yatani A, Brown AM, Akaike N. Effect of extracellular pH on sodium current in isolated, single rat ventricular cells. *J. Membr. Biol.* 1984; 78(2):163-168.
- [8] Irisawa H, Sato R. Intra- and extracellular actions of proton on the calcium current of isolated guinea pig ventricular cells. *Circ. Res.* 1986; 59(3):348-355.
- [9] Coronel R, Fiolet JW, Wilms-Schopman FJ, Schaapherder AF, Johnson TA, Gettes LS et al. Distribution of extracellular potassium and its relation to electrophysiologic changes during acute myocardial ischemia in the isolated perfused porcine heart. *Circ.* 1988; 77(5):1125-1138.
- [10] Heidenreich E, Romero L, Rodríguez JF, Trénor B, Saiz J, Ferrero JM, Doblaré M. Vulnerability to Reentry in a 3D Regionally Ischemic Ventricular Wedge Preparation: A Simulation Study. *Computers in Cardiology* 2007;34:321-324.
- [11] Romero L, Trenor B, Ferrero JM (Jr), Saiz J, Moltó G, Alonso JM. Safety Factor in Simulated 2D Cardiac Tissue. Influence of Altered Membrane Excitability. *Computers in Cardiology* 2006;33:217-4.
- [12] Romero L, Trenor B, Ferrero JM (Jr), Saiz J, Moltó G, Alonso JM. The safety factor approach in the analysis of reentrant patterns of activation in the ischemic virtual heart. *Computers in Cardiology Conference* 2007;34:317-4.

Address for correspondence

Lucía Romero Pérez
Universidad Politécnica de Valencia
Camino de Vera s/n
46071 Valencia
Spain
E-mail: lurope@doctor.upv.es